

Model No.: SC600 Swing Check Valve

Sizes range:	1/2" ~ 3" (DN 15 ~ DN 80)
Working pressure:	600 PSI
Temperature rating:	- 20°F ~ 400°F (- 29°C ~ 200°C)
End connection:	Threaded
Seat materials:	PTFE Gasket packing

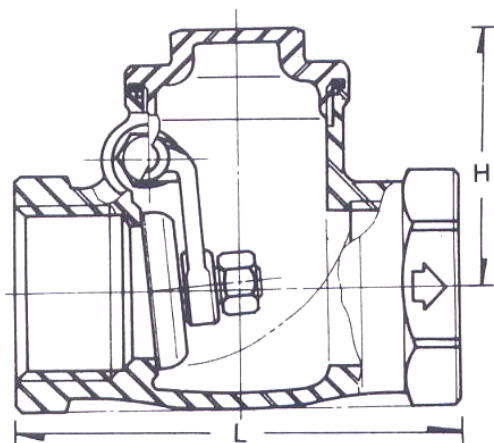
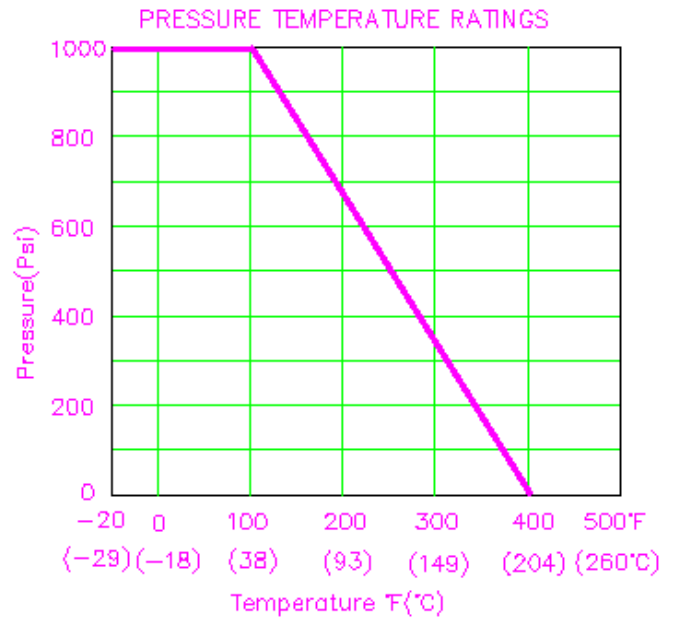
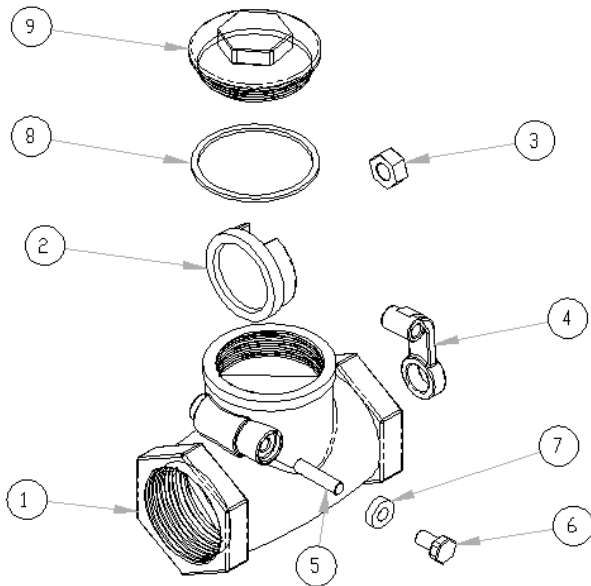

MATERIAL LIST

NO	PART NAME	Q'ty	SPECIFICATION
1	Body	1	304, 316, CF8M
2	Disc	1	304, 316, CF8M
3	Disc nut	1	304
4	Connecting rod	1	304, 316, CF8M
5	Pin	1	304, 316
6	Bolt	1	304
7	Bolt Washer	1	Teflon
8	Gasket	1	Teflon
9	Cap	1	304, 316, CF8M

DIMENSIONS(mm)

SIZE	1/2	3/4	1	1 1/4	1 1/2	2	2 1/2	3
L	60.0	78.0	84.0	94.0	104.0	122.0	153.0	175.0
H	41.5	46.0	49.0	53.5	58.5	67.0	105.0	125.0
Weight/kgs	0.29	0.53	0.69	0.85	1.20	1.80	3.50	5.00