

- Size range: 1/4" ~ 4"(DN 8 ~ DN 100)
- Port availability: Full Port.
- Working pressure: 1000 WOG
- Temperature range: - 20°F ~ 400°F (- 29°C ~ 200°C)
- Body material: CF8M(1.4408) or CF8(1.4308) or WCB(1.0619)
- Trim material: Stainless Steel Ball & Stem.
- End connection: Threaded.
- Seat material: PTFE.
- Blow-out proof stem design
- Adjustable stem packing
- Available with threaded holes at the body for actuator mounting
- Available with handle locking plate



Two Piece Ball Valves

DIMENSIONS (inch)

SIZE	ØD	E	H	L	X	W (kg)	Cv FACTOR
1/4"	11.6	100	51	53	30	0.23	6.0
3/8"	12.5	100	51	53	30	0.23	12.0
1/2"	15.0	97	49	57.5	34	0.28	19.0
3/4"	20.0	120	58	64	42	0.44	37.0
1"	25.0	150	68	79	48	0.68	64.0
1 1/4"	32.0	150	73	92.5	61	1.06	103
1 1/2"	38.0	164	87	104.5	72	1.62	143
2"	50.0	164	95	116.5	88.5	2.52	360

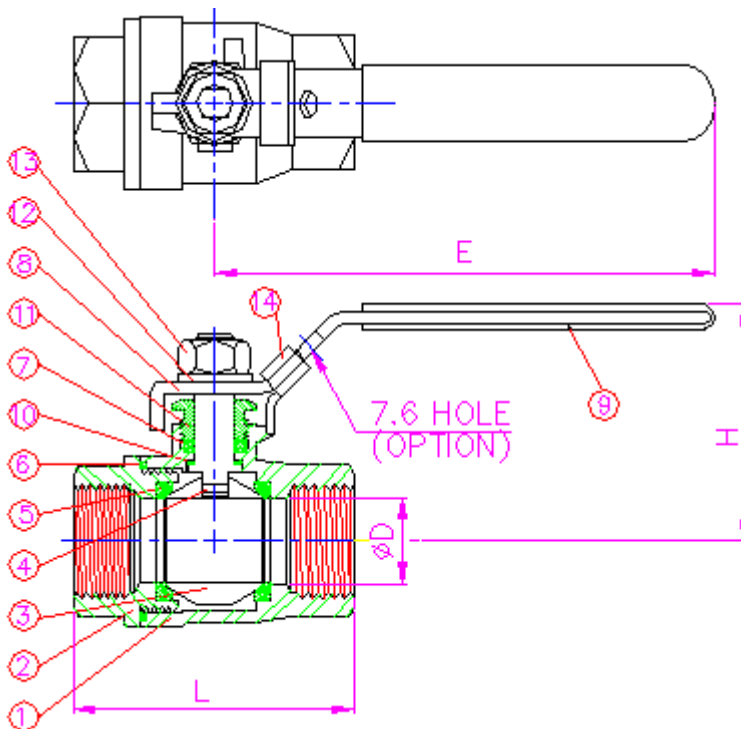
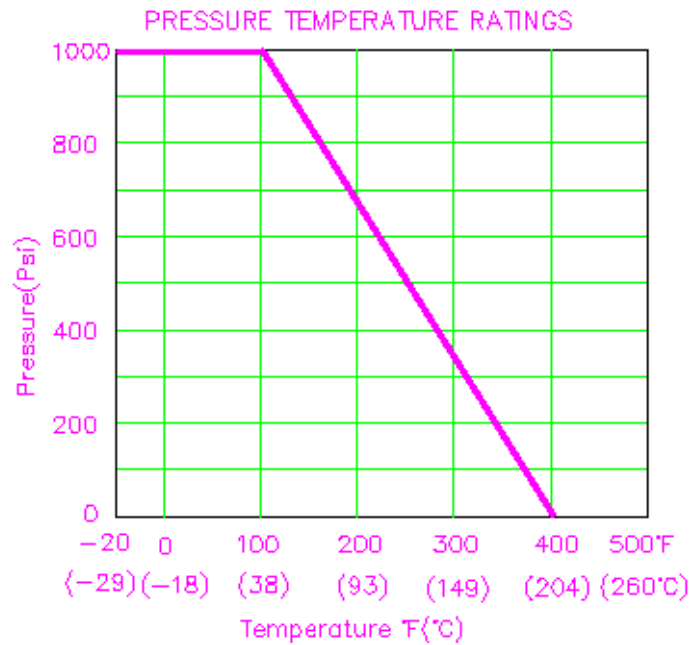

MATERIALS LIST

No.	PART NAME	SPECIFICATION
1	BODY	ASTM A351 GR.CF8M
2	END CAP	ASTM A351 GR.CF8M
3	BALL	ASTM A351 GR.CF8M
4	STEM	S.S.316
5	BALL SEAT	PTFE
6	END SEAL	PTFE
7	STEM PACKING	PTFE
8	HANDLE	S.S.304
9	HANDLE SLEEVE	VINYL GRIP
10	THRUST WASHER	PTFE
11	GLAND	S.S.304
12	HANDLE WASHER	S.S.304
13	HANDLE NUT	S.S.304
*14	LOCKING PLATE	S.S.304

*optional