

- 1-Piece Ball Valve Polished Hexagonal Type
- Sizes range: 1/4"~ 2" (DN 8 ~ DN 50)
- Port availability: Reduce port
- Working pressure: 1000WOG (PN63)
- Temperature rating: - 20°F ~ 400°F (- 29°C ~ 200°C)
- Body material: CF8M(1.4408) or CF8(1.4308) or WCB(1.0619)
- Trim material: Stainless Steel Ball & Stem
- End connection: Threaded
- Seat material: PTFE
- Blow-out proof stem design



One Piece Ball Valves

DIMENSIONS (inch)

SIZE	d	D	H	E	L	Cv FACTOR	W(kg)
1/4"	5	17.5	30	60	41.5	1.0	0.08
3/8"	7	21	30	80	47	2.5	0.12
1/2"	9.2	25	54	90	57	5.5	0.19
3/4"	12.5	32	66	100	64	10.0	0.32
1"	15	38	68	110	74	15.5	0.50
1 1/4"	20	48	71	110	88	20.0	1.89
1 1/2"	25	55	75	130	96	37.0	1.23
2"	32	68	80	130	108	60.0	1.97

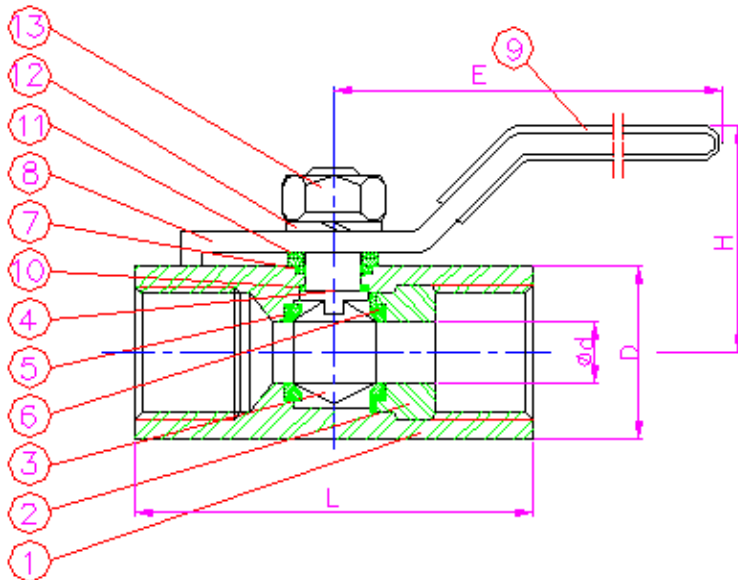
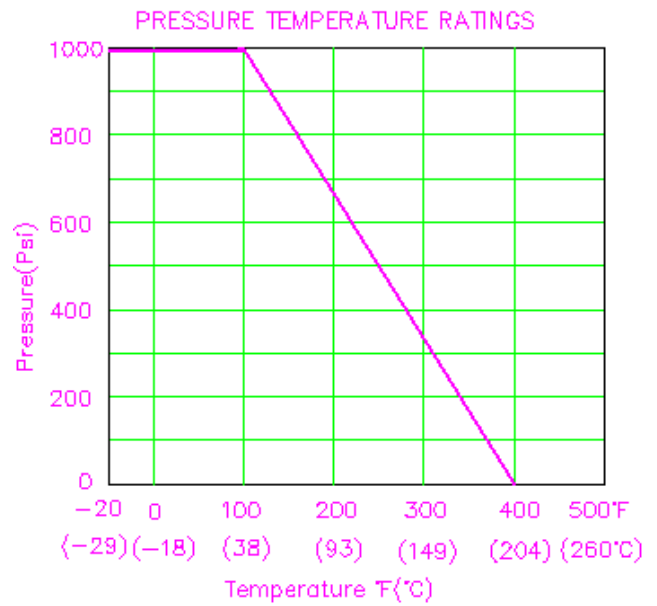
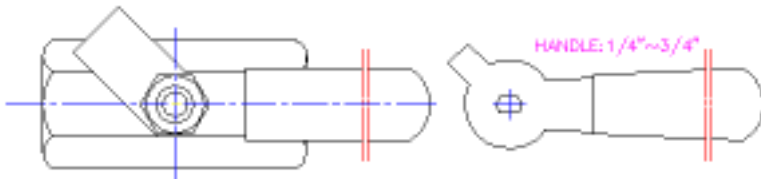

MATERIALS LIST

No.	PART NAME	SPECIFICATION
1	BODY	ASTMA351 GR. CF8M
2	INSCREWED SEAT RETAINER	S.S.316
3	BALL	ASTMA351 GR. CF8M
4	STEM	S.S.316
5	BALL SEAT	PTFE
6	CAP SEAT	PTFE
7	PACKING	PTFE
8	HANDLE	S.S.304
9	HANDLE SLEEVE	VINYL GRIP
10	THRUST WASHER	PTFE
11	GLAND	S.S.304
12	WASHER	S.S.304
13	HANDLE NUT	S.S.304